



# DANS L'ESPACE

Show by Cie Un Loup Pour l'Homme  
Touring since November 2022  
For 4 circus artists, 2 musicians  
and 2 technicians

## TECHNICAL SHEET - TENT

Please read these technical specifications carefully since they guarantee the company's comfort as well as the show's success. This document and its appendix are an integral part of the contract and must be returned duly initialled and signed. Please respect these technical specifications as much as possible and inform the production coordinator in case of an impediment, even if only partial. Any changes will need to be reported to him and written on this same technical sheet.

UPDATE NOVEMBER 2023



Un Loup Pour l'Homme / 27 rue Jean Bart / 59000 Lille  
Rémi Athonady / +33 687 26 26 89 / [technique@unlouppourlhomme.com](mailto:technique@unlouppourlhomme.com)  
[www.unlouppourlhomme.com](http://www.unlouppourlhomme.com)

# THE TENT



Round tent of 18,50m diameter, opaque interior, exterior colour: Basque red and interior colour : Midnight blue.

Circus tent, arch-shaped support structure (similar to the Eiffel's triangular structure), circular dome, no cornice poles, apsic walls.

2 entrances/exits of 1.80m wide, location to be defined with the production coordinator depending on the venue choice.

Supporting structure tent and canvases approved of on March 16 2009. Last inspection on 2021 (valid until 2023) and next inspection planned in April 2024.

Equipment : 2 water extinguishers (6 liters) + 1 CO2 fire extinguisher (2kg)

6 self-contained emergency lighting of 45 lumens (BAES) + 2 self-contained emergency lighting of 1000 lumens in the dome.

Register extract available on request

## **Dimensions of the tent : (plans in appendix 1)**

Interior : 18.50m (round diameter)

Stake circle diameter : 24.50m

Rigging perimeter : 24.50mx28m

Height of the dome : 7m

Height of the arch : 11.10m

Height of the walls : 3.20m (36 tower posts of 60mm diameter)

58 clamps of 35mm diameter and 1.20m long as well as 8 clamps of 30mm diameter and 0.80m long.

The organiser is required to perform a test when the clamps are being removed.

## **Bleachers / seats : (plan in appendix 2)**

SAMIA circular bleachers, 5 rows, capacity of 354 seats

2 passageways of 1.40m and 1 passageway of 90cm

Our bleachers allow us to also welcome 5 Persons with Limited Mobility (PLM) maximum. For that, we need to take away a few benches in order to create a large enough space. As a result, we need to count 5 seats for a single PLM one. The organiser will need to inform the production coordinator during the arrival of PLM so as to welcome them appropriately.

## **Flooring:**

Wooden floors laid onto beech joists for the circus ring as well as the circulation of spectators near the entrance of the bleachers.



Un Loup Pour l'Homme / 27 rue Jean Bart / 59000 Lille

Rémi Athonady / +33 687 26 26 89 / [technique@unlouppourlhomme.com](mailto:technique@unlouppourlhomme.com)

[www.unlouppourlhomme.com](http://www.unlouppourlhomme.com)

**Surface:*****Type of surface and location choice:***

The surface must be stable, flat, horizontal, flood-proof, mud-proof and homogeneous.

A surface ground preferably sheltered from the wind and other bad weather conditions.

On earthy soil, foresee the use of slatted floors, screens, gravel beds, rubber tiles or other at the 2 entrances. In case of a particularly hard surface, the organiser will have to provide a good quality hammer drill with an adapted drill (35mm in diameter and 600mm long) upon arrival of the troupe and until two days before the show.

In case of a grass surface, please schedule a low mowing session before the troupe's arrival.

If possible, avoid surfaces near noisy installations (factories, construction sites, motorways, railways...).

***Underground and overhead lines:***

The organiser must provide a layout and site plan of the underground clearly indicating where the networks are located (Electricity, Gaz, waste- and rain-water, telephone, etc.) for the use of clamps.

**In case the pipelines are below ground, the organiser must imperatively share this information 3 days before the show, at the latest, and inform the fitter of their exact location, type and how deep they are buried below ground.**

The troupe shall under no circumstances be held responsible for the damage of a pipeline if it didn't have prior knowledge of their presence.

No power or telephone lines are allowed above the location area.

If necessary, let the tent manager and/or production manager initiate an inspection of the location, covered by the Organiser.

**Site security:**

The chosen plot of land must have at least 2 exits (for fire brigade intervention).

Allow a free access of a 5m clearance width starting from the stakes till at least ½ of the tent's perimeter for emergency vehicle access.

Use steel metal barricades depending on the location choice from the start of the assembling process (security perimeter during the assembly and disassembly processes).

The Organiser is in charge of the security according to the schedule defined in agreement with the production coordinator.

**Unloading space:**

This space must be accessible for a Heavy Vehicle with a tailgate + 1 truck trailer.

Overall length : 25m. Height: 4.12m. Width: 2.50m.

Keep the type of surface in mind : a Heavy Vehicle can easily get stuck in wet soil/mud.

The organiser must provide a city map with the access routes for Heavy Vehicles.



# THE CAMPSITE



The company travels in convoy, in other words with a set of vehicles and caravans.

## **Composition :**

The convoy is composed of (at least) :

1 Heavy Vehicle + 1 Heavy Vehicle trailer

7 passenger cars + caravans

The campsite has at least 10 mobile homes (camping cars or caravans). The other vehicles will need to be stationed nearby.

Touring staff: 10 people : 6 artists, 2 technicians, 1 logistic manager and 1 production manager . Depending on the location, the number of people present may vary, in which case the Organiser will be informed.

## **Surface:**

The campground must be in the direct vicinity of the tent for safety reasons (maintenance in case of bad weather, among others). It must be a flat surface, flood-proof, mud-proof and accessible for motor vehicles (maximum height : 4m, maximum width : 2.5m, maximum length : 8m).

The campground chosen for the tent and campsite are not only the performance space but also the working and living place of our company members throughout their entire stay.

The campground choice is your responsibility but a green area with trees is most welcome.

## **Security:**

If the campsite isn't anywhere near the tent, the organiser will provide security for the tent outside of working hours and for the campsite during working hours (schedule to be determined with the production coordinator).

Security is also to be provided during meal times in the event that these were not to be given on-site.

During lengthy stays, security will also need to be provided during OFF days.

## **Internet:**

To the extent possible, an Internet connection on the campsite itself or nearby for the company is more than welcome.



Un Loup Pour l'Homme / 27 rue Jean Bart / 59000 Lille

Rémi Athonady / +33 687 26 26 89 / [technique@unlouppourlhomme.com](mailto:technique@unlouppourlhomme.com)

[www.unlouppourlhomme.com](http://www.unlouppourlhomme.com)

# Logistics

## Facility connection :

The electricity, water and sanitary facilities must all be connected and operational from the company's arrival until its departure.

The electrical connections must be carried out by authorised staff at the expense of the organiser. The organiser will also need to provide cable guards in sufficient quantities.

## Electricity :

### *Tent :*

A Tetrapolar 63A, stabilised and standardised P17 63A, for the entire tent (lighting and sound).

The electrical cabinet with a 30mA differential protection, is provided by the troupe.

### *Campsite:*

A Tetrapolar 32A, stabilised and standardised P17 32A, for the campsite.

The 32A electrical cabinet is provided by the troupe.

Important: depending on the season, a Tetrapolar 63A power supply may also be requested for the campsite. In this case, the organiser will need to provide an electrical cabinet of 12 220v and 16A mono minimum circuits.

**IMPORTANT: The two power supplies (tent and campsite) must IMPERATIVELY be separate.**

If the electrical requests were not to be respected, the rental of a soundproof and regulated generator set will have to be considered for the tent.

In this case, it's important to check with the lessor that the fuel filters were changed and make it clear that they are going to be used for entertainment purposes (thus electrical) and must therefore be of good quality.

## Telescopic Forklift :

The organiser will have to provide a telescopic forklift « type buggy » with forks. The forklift will have to be available for the tent building day (from very early morning / all day long) and for the day after the last show (from very early morning / all day long).

## Heating :

Depending on the season and weather, it may be necessary to heat the tent during the assembly process, adjustments, rehearsals and performances.

The company has a heating system (SECOMAT 110kW max) as well as a 1000l double-walled fuel tank.

The organiser will be responsible for the supply of fuel oil. The schedule times will be determined in agreement with the production coordinator. For your information, the average consumption is 12 litres/hour.

## Sanitary Facilities and Toilets :

The organiser is in charge of installing heated sanitary facilities on-site : 2 toilets + 2 showers minimum + sinks (hot water in quantity for 10 people). These sanitary facilities are reserved exclusively for the company members.

The organiser is also responsible for the cleaning of the sanitary facilities, at least 3 times a week.

The organiser will make sure that there are different sanitary facilities for the audience.

## Garbage bins :

Provide, near the campsite, two containers for household garbage, one glass container as well as one selective sorting container (according to the city's policy).

Also make sure that the garbage is collected regularly.



Un Loup Pour l'Homme / 27 rue Jean Bart / 59000 Lille

Rémi Athonady / +33 687 26 26 89 / [technique@unlouppourlhomme.com](mailto:technique@unlouppourlhomme.com)

[www.unlouppourlhomme.com](http://www.unlouppourlhomme.com)

**Catering Services:**

Depending on the reception conditions, a sheltered and heated catering area must be provided by the organiser. As this area is the common living space of all company members, a floor decking would be appreciated.

This area must be available from the company's arrival until its departure.

Tables and chairs will need to be set up in sufficient quantities.

So as to limit the excessive consumption of plastic water bottles, the company would rather have access to a drinking water source on the campsite itself.

## Miscellaneous

**Welcoming the public:**

The company also has a 6mx6m tent, approved and attached to the tent, from the same manufacturer (VSO) and with the same colours, which helps create a place for welcoming the public at the entrance and/or at the exit of the tent.

**Weather forecast:**

The organiser will need to pay particular attention to weather impairments and, if necessary, inform the production coordinator in case the wind exceeds 60km/h.

The producer reserves the right to question the show's performance in case of weather-related risks. If winds exceed 100km/h or if there's a snowfall of more than 4cm, the public will need to be evacuated from the tent. Either way, the head tent builder of the company's tent can decide whether or not the show will be performed during potentially dangerous weather conditions.



Un Loup Pour l'Homme / 27 rue Jean Bart / 59000 Lille

Rémi Athonady / +33 687 26 26 89 / [technique@unlouppourlhomme.com](mailto:technique@unlouppourlhomme.com)

[www.unlouppourlhomme.com](http://www.unlouppourlhomme.com)

# SCHEDULE OF THE ASSEMBLY PROCESS / HUMAN NEEDS

## **3 days before : Arrival of the convoy / camp set up / tent layout**

1 reception host + 1 electrician (electrical cabinet connection)

## **2 days before : Building of the tent + floors + bleachers (in addition to the company's technical team)**

9am-1pm : Building of the tent + floors + bleachers : 7 tent builders (6+1 forklift driver)

2pm-7pm : Building of the tent + floors + bleachers + sound and lighting editing : 2 stagehands, 1 sound director, 2 lighting directors and 1 electrician

## **1 day before : Technical assembly inside the tent (in addition to the company's technical team)**

9am-1pm : Sound and lighting editing : 3 stagehands, 1 sound director, 2 lighting directors and 1 electrician

2pm-7pm : Sound and lighting editing : 2 lighting directors

## **D-Day (variable according to the performance hours) :**

10am-1pm : Adjustments and finishing touches if needed : 1 reception manager

2pm-7pm : Rehearsals : 1 reception manager

Evening : show : 1 production coordinator / 3 reception hosts (not included are the people responsible for the ticket booths, ticket control and flyer distributions)

After the show : Meeting with the costume designer to retrieve the costumes

## **The following days :**

2pm-7pm : Warm-up, rehearsals, general cleaning and costume cleaning : 1 production coordinator / 1 costume designer

Evening : show : 1 production coordinator / 3 reception hosts

**After the last show**, during 2 hours : Technical dismantling (sound and lighting) : 3 machinists, 1 sound director, 2 lighting directors and 1 electrician (ideally, the same team daily until the day before the show)

## **The day after the last show (or after the last show, depending on the time):**

9am-1pm/2.30pm-6pm : Dismantling of the bleachers, stage and tent : 6 tent builders (ideally, the same team as 2 days before the show)



Un Loup Pour l'Homme / 27 rue Jean Bart / 59000 Lille

Rémi Athonady / +33 687 26 26 89 / [technique@unlouppourlhomme.com](mailto:technique@unlouppourlhomme.com)

[www.unlouppourlhomme.com](http://www.unlouppourlhomme.com)

# TECHNICAL EQUIPMENT AND SCENOGRAPHY

The show takes place in a circular stage. The artists move on a central stage 12m diameter.

## **Structure:**

The company has all the structural equipment to hang technical equipment:

- \_A 6m diameter truss – ASD SZ290 FC square
- \_Lifting chains
- \_Safety slings
- \_Stem tube diameter 50mm

## **Light:**

**To be provided by the Organizer:**

- \_2 PAR 64 CP 61 with hook, safety sling and filter holder (no P17).**
- \_4 profil Robert Juliat 613 SX, with hook, safety sling and filter holder (no P17) +6 lee 763 and 2 lee 212**
- \_3 profil Robert Juliat 613 SX, with plate (no P17).**
- \_4 PC 1 kw with hook, safety sling, flaps and filter holder (no P17) + 4 lee 763**
- \_2 multipair light 25m (no P17)**
- \_20 electrical wire 10m (no P17)**
- \_20 electrical wire 5m (no P17)**

Provided by the company:

- 28 PAR 64 LONG
- 12 PER 64 courts
- 30 black IP20 plastic hand lamps (public circulation and bleachers)
- 3 HPIT 40W asymmetric (services)
- 2 dimmers R. JULIAT 24x3kW
- 1 MACBOOK computer + ENTTEC case
- DMX cables

## **Sound :**

**To be provided by the organizer:**

- \_1 sub bass (ideally HK audio PR: O 18S or PR: O 210S or equivalent, 1 specific start)**
- \_2 bass speakers (type L-acoustics X15)**
- \_Power amplifiers corresponding to the equipment available, as well as the necessary wiring to connect them to the speakers from the control desk ( 30m)**

In case the sound equipment provided by the organizer is in adaptation to the available stocks, thank you to bring to our knowledge the references of the selected models.





### **Costume Maintenance:**

The pieces will be given to the person in charge of maintaining the costumes after each performance. This person will make sure to bring them back to the performance the day of the next show, at least 4 hours before the beginning of the show. The dressmaker will have to check the good condition of the costumes and if necessary, carry out the repairs after close consultation with the general manager of the company.

The costumes are in two different shades: light blue and dark blue.

The light blues will be machine washed together at 30 degrees max or cold, with a color protective product.

Dark blues will be machine washed together at 30 degrees max or cold, with a color protective product.

All costume pieces can be ironed.

## **CONTACTS**

General technical coordination : Rémi Athonady / +33 687 26 26 89

[technique@unlouppourlhomme.com](mailto:technique@unlouppourlhomme.com)

Head of production : Lou Henry / +33 659 44 50 43

[diffusion@unlouppourlhomme.com](mailto:diffusion@unlouppourlhomme.com)

Logistics : Emma Lefrançois / +33 674 32 78 17

[emma@unlouppourlhomme.com](mailto:emma@unlouppourlhomme.com)



Un Loup Pour l'Homme / 27 rue Jean Bart / 59000 Lille

Rémi Athonady / +33 687 26 26 89 / [technique@unlouppourlhomme.com](mailto:technique@unlouppourlhomme.com)

[www.unlouppourlhomme.com](http://www.unlouppourlhomme.com)

# APPENDIX 1 : GENERAL VIEW

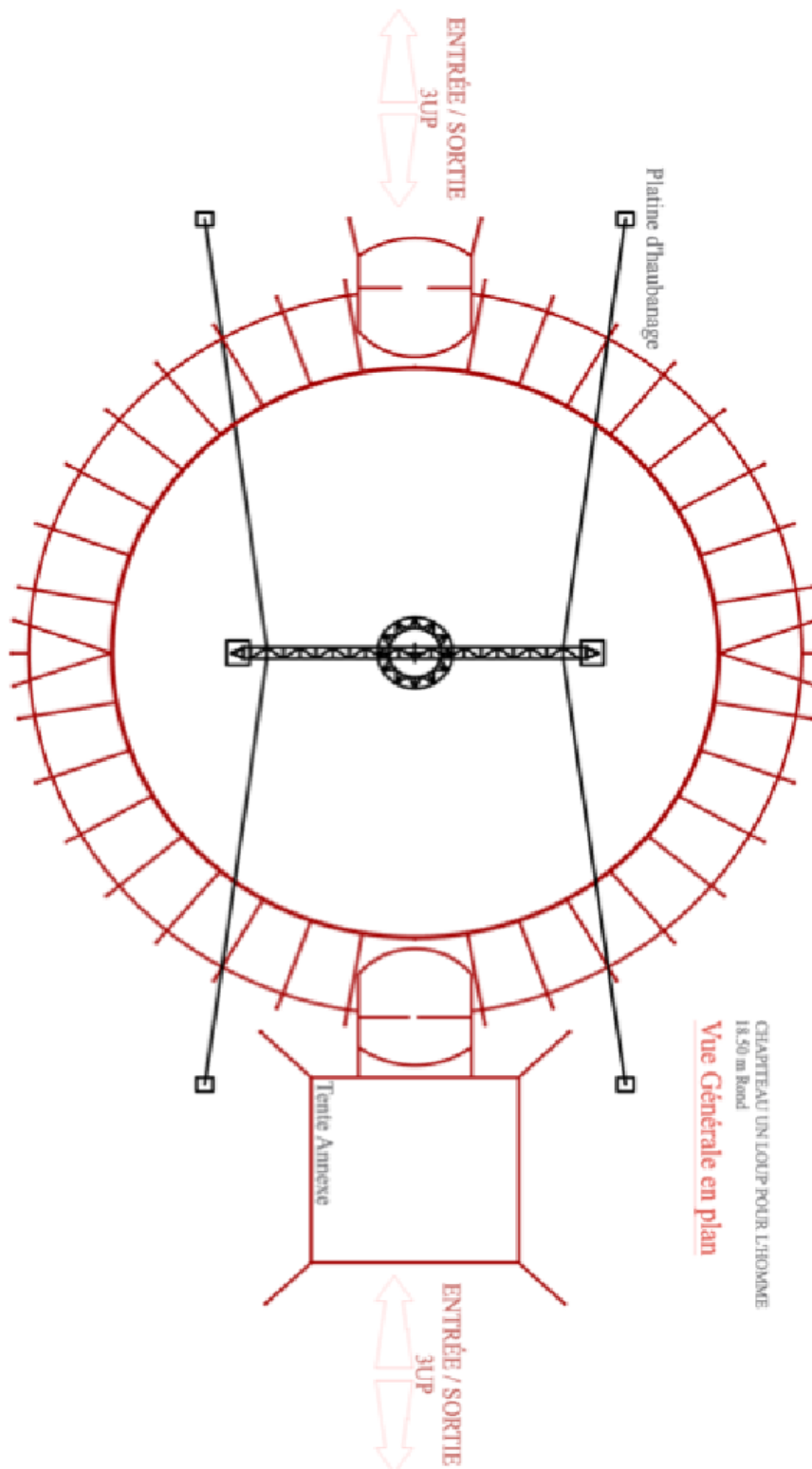

UN LOUP  
POUR  
L'HOMME

Un Loup Pour l'Homme / 27 rue Jean Bart / 59000 Lille  
Rémi Athonady / +33 687 26 26 89 / [technique@unlouppourlhomme.com](mailto:technique@unlouppourlhomme.com)  
[www.unlouppourlhomme.com](http://www.unlouppourlhomme.com)

# APPENDIX 1 : TENT DIMENSIONS

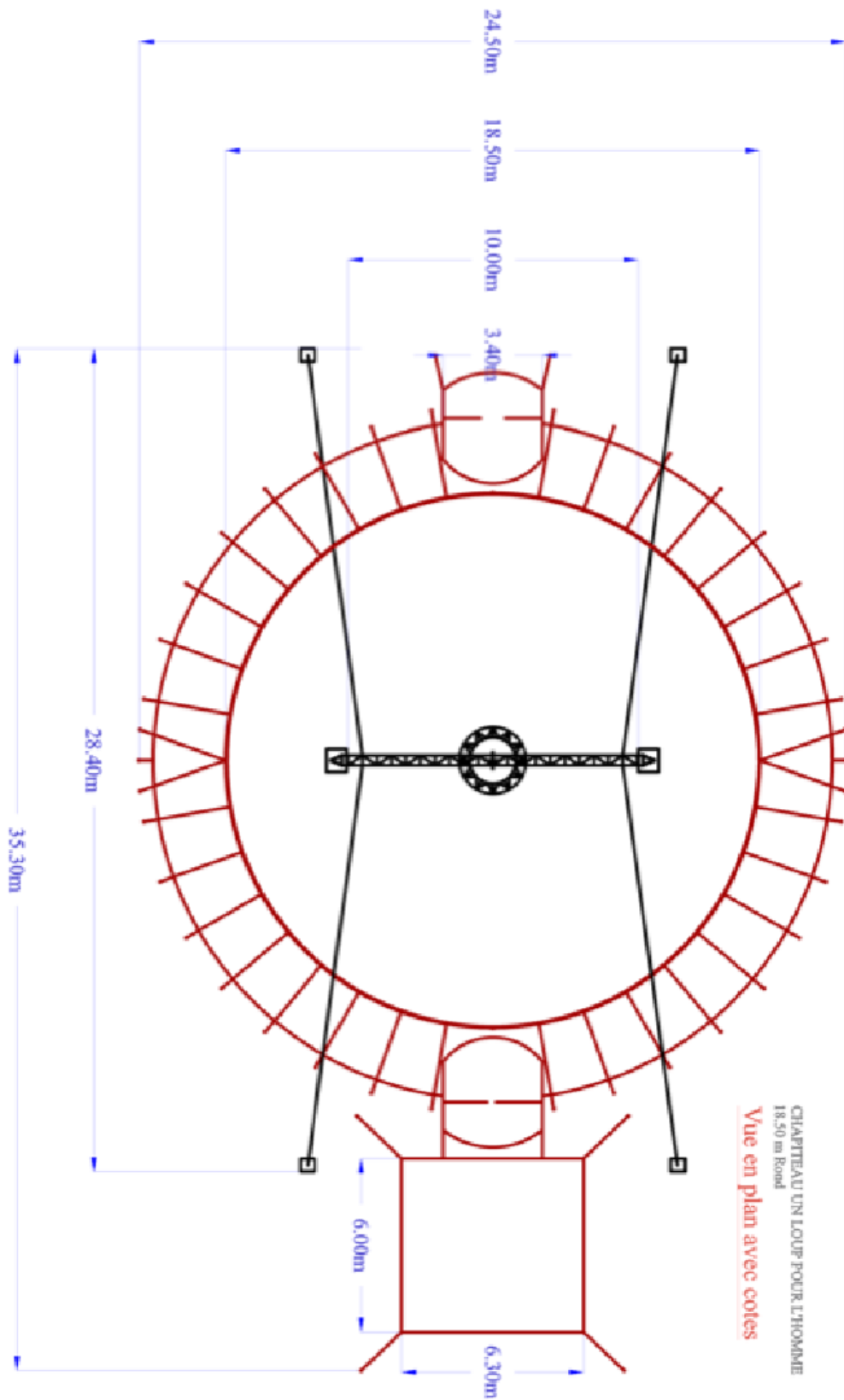

## APPENDIX 2 : BLEACHERS

